

Investigating the Feasibility of Solar Wind Hybrid Systems for Off-Grid Rural Areas

Pavan Chitta

Center for Fundamental Research and Creative Education

Abstract: The study investigated the viability of using hybrid models of renewable power generation in certain geographical areas where the climate is suitable. A real model of the set-up was created and the data obtained was compared to simulated models to improve accuracy. The data from both the real set-up and the simulated model were then compared to climatic conditions in certain rural areas of India. As of submission of this report, wind is not a prevalent source of energy in the southern Indian state of Karnataka; this project aims to conclude whether such non-utilisation is justified or whether it would be beneficial if such hybrid models be used in certain areas of suitable conditions.

Keywords: Hybrid Models, Investigated The Viability, Off-Grid Rural Areas.

1. INTRODUCTION

It has undoubtedly come to the attention of the global community that Renewable Energy is very essential for the clean and safe future of our world. Fossil fuels are finite and cause environmental pollution and global warming. With several ongoing climate debates, there is mutual consensus that developing countries are some of the major causes of global warming and pollution; few of these nations include India and China. A report by the United Nations Environmental Programme (UNEP) claims that actions on renewable energy and energy efficiency in developing countries could reduce emissions by 1.7 Gigatons/year by 2020⁽¹⁾.

The consequences of global warming are evident through the existence of rising sea levels, rising average global temperatures and extreme climatic conditions. In India, prolonged droughts are taking a heavy toll on farmers during the summer. In contrast, the monsoon season is bringing heavier rains than ever before. The frequency of cyclones and other extreme weather conditions has increased, with recent cases such as that in Chennai having adverse effects.

Thus, the need for eradicating the fossil fuel centered energy system and replacing it with sustainable, renewable energy is significant. In many countries, including India, another problem is that many village households are off the grid, disconnected from the central power grid supply system. It has become very difficult for such households to obtain a continuous supply of electricity for daily activities.

With regards to this problem, Prime Minister of India, Modi promised to light up all villages by the year 2022. There are 18,000 villages which do not have power. Modi has highlighted the advantages of solar power, but the possibility of a solar-wind hybrid has not been given serious thought. It is entirely possible, however, that such a hybrid could be advantageous in certain vicinities where wind is abundant. This system, for example, could work particularly better than other individual models one of the input factors is absent. For example, during the night, in coastal areas as winds pick up, lack of sunlight will be compensated for by the abundance of wind energy.

2. SOLAR ENERGY

Solar Energy is produced using Photo Voltaic (PV) Cells, which when exposed to Sun convert the Photons into electricity. Photons from the Sun react with the semiconductor material in the PV cell, releasing the electrons, which produces electricity. Each PV Cell is connected to form an array of solar panels.

A PV cell contains two layers of semiconductor material made up of silicon crystals. Crystallized silicon is not a very good conductor of electricity on its own, so impurities are added for enhanced conductivity through the process called doping. The bottom layer of the PV cell is usually doped with boron (3 valence electrons), which bonds with the silicon to facilitate a positive charge (P). The top layer is doped with phosphorus (5 valence electrons), which bonds with the silicon to facilitate a negative charge (N). The surface between the resulting "p-type" and "n-type" semiconductors is called the P-N junction.

When sunlight enters the cell, its energy knocks electrons loose in both layers. Because of the opposite charges of the layers, the electrons want to flow from the n-type layer to the p-type layer, but the electric field at the P-N junction prevents this from happening. The presence of an external circuit, however, provides the necessary path for electrons in the n-type layer to travel to the p-type layer. Extremely thin wires running along the top of the n-type layer provide this external circuit, and the electrons flowing through this circuit produce electricity.

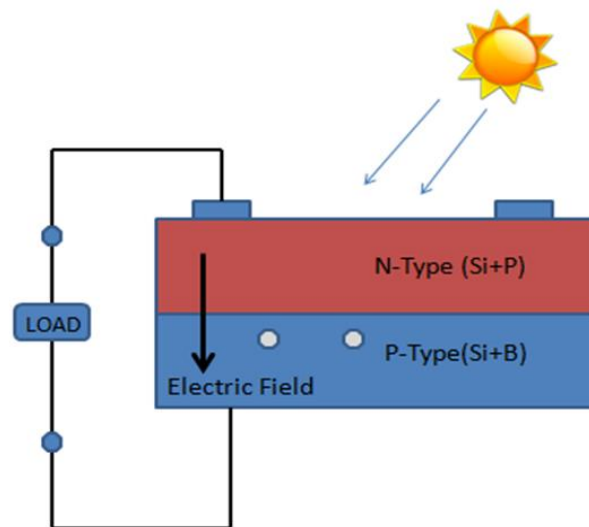

Fig 1. Solar Cell

3. WIND ENERGY

Wind energy is produced by harnessing Wind's Kinetic energy and converting it into Electricity. Wind mills contain three or more propeller blades which turn the rotor, which is connected to the main shaft. The rotor in turn spins a generator to create electricity. There are 2 types of wind turbines, vertical axis and horizontal –axis:



Vertical Axis

Horizontal Axis

Fig 2. Types of Wind Mills

In a wind energy system, the mechanical power is delivered to the rotor of an electric generator where this energy is converted to electrical energy. The rotor converts the kinetic energy of the wind flow into mechanical energy, which moves the rotor blades. The generator converts this mechanical energy from the motion of rotor into electrical energy through electro-magnetic induction.

Wind power generated depends upon:

1. amount of air (Volume)
2. speed of air (Velocity)
3. mass of air (density)
4. flowing through the area of interest (flux)

Wind energy is also impacted by the losses incurred during the transmission of kinetic energy to mechanical energy and generator losses during the transmission of mechanical energy to electrical energy. Wind mills perform at a certain percentage of the rated capacity, called the capacity factor C_f , which varies based on the wind speed and other natural factors. Wind mill turbine efficiency increases as wind speed increases, but at very large speeds the efficiency tapers off. Thus, there is an optimal speed at which the turbine efficiency is the best. The power captured by the turbine is a fraction of the available power, which is called coefficient of performance C_p .

4. OBJECTIVE AND DESIGN

One objective of this project was to design a Solar-Wind hybrid system to light up a typical Rural home with few light bulbs and a fan for 4-6 hours. The basic power requirements for these appliances are listed below:

Power requirement:

| Connected Load | Watts | Hours | Watt Hours |
|----------------|-------|-------|------------|
| CFL | 7 | 5 | 35 |
| CFL | 7 | 5 | 35 |
| DC FAN | 6 | 5 | 30 |
| | 20 | 15 | 300 |

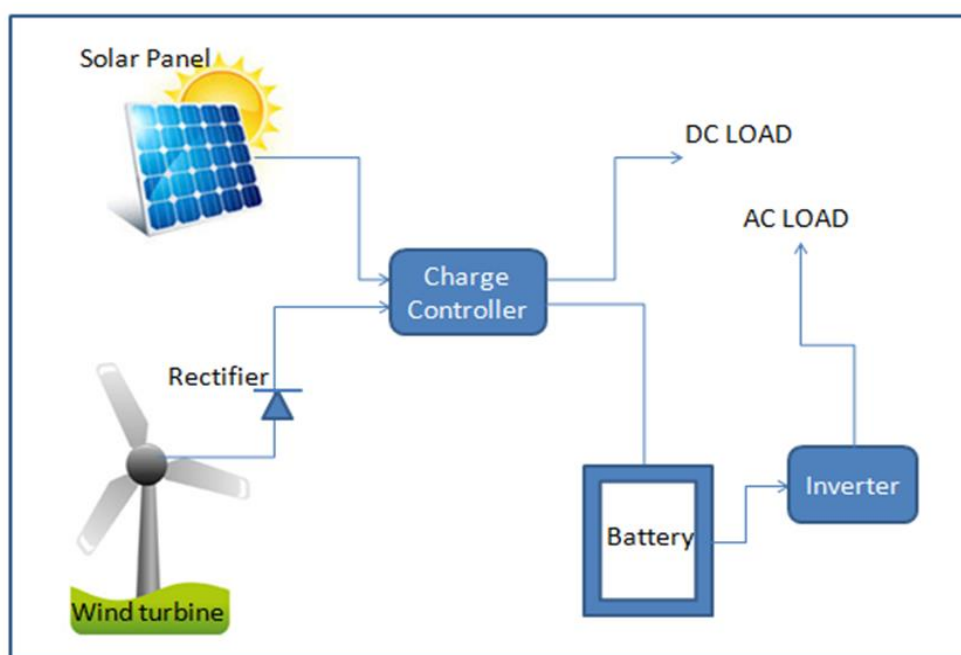

Fig 3. Hybrid Solar-Wind System

PV Panel - Solar Calculations:**Specifications of material used:**

Solar panel = 20 watts

Battery Capacity = 15 aH

Battery Voltage = 12 Volts

Assumptions:

Hours of good sunlight availability = 8 Hours

Combined Efficiency = Battery Efficiency × Inverter Efficiency

= 0.92 × 0.92 = 0.85 = 85%

Operating factor of the Solar Panel is set at 75% of the rated output, which depends on the temperature, dust etc.

- **Actual power output of PV Panel : Peak power rating * operating factor**

Peak Power rating of the Solar Panel = 20 Watts

Operating factor of the Solar Panel = 0.75 (from the assumptions)

Actual power output = 20 × 0.75 = 15 watts

- **Actual power at the end use is: Actual power output of a panel * combined efficiency**

Combined efficiency = 0.85 (from the assumptions)

Actual power at the end use = 15 × 0.85 = 12.75 watts

- **Energy produced by one 20 W panel in a day**

Actual power output × 6 hours/day = 12.75 × 6 = 76.5 WH

Power Requirement for a rural house = 100WH

Energy from Solar Panel = 76.5 WH

Requirement from wind power = 30 WH

Wind - Turbine Rating Calculations:**Assumptions:**

- *Wind speed = 15 Km/h = 4.1 m/s*
- *Density of air (ρ) = 1Kg/m³*
- *Coefficient of performance (C_p) is the ratio of the power extracted by the turbine to the total contained in the wind resource = 0.45*
- *Transmission efficiency (Rotor to generator - T_p) = 0.9*
- *Generator efficiency (G_p) = 0.9*
- *Capacity factor = 0.3 (30% of the time it is producing energy at rated power)*
- *No. of hours of wind = 16*
- **Kinetic Energy:** $KE = \frac{1}{2}mv^2$
- **Power of wind (KE per unit time)**

$$P = \frac{1}{2} \times \dot{m} \times v^2$$

$$\text{Mass flow rate (density} \times \text{Volume flux)} = \dot{m} = \frac{dm}{dt} = \rho \times A \times v$$

$$P = \frac{1}{2} \times \rho \times A \times v^3 = 0.5 \times 1 \times (4.1 \times 4.1 \times 4.1) = 34.4 \text{ watt/m}$$

- **Overall loss factor = Coefficient of performance x transmission loss x generator loss**

$$\text{Overall Loss Factor} = C_p \times T_p \times G_p = 0.4 \times 0.9 \times 0.9 = 0.324$$

- **Actual power density = Power of wind x Overall loss factor**

$$34.4 \times 0.324 = 11.165 \text{ w/m}^2$$

- **Daily energy density = Actual Power density x No. hours of wind**

$$11.165 \times 16 = 178.64 \text{ wh/m}^2$$

- **Total energy required = 30 Wh (from previous calculations)**

- **Turbine power rating estimation:**

$$\text{Area of the rotor blade} = \text{Total annual energy required} / \text{Useful energy density}$$

$$30 \text{ wh} / 178.64 \text{ wh} / \text{m}^2 = 0.17 \text{ m}^2$$

$$\text{Area of the rotor blade} = 0.17 \text{ m}^2$$

$$\begin{aligned} \text{Power rating of the wind turbine} &= \text{Actual power density} \times \text{area of the rotor} = 11.165 \text{ w/m}^2 \times 0.17 \text{ m}^2 \\ &= 1.9 \text{ w} \end{aligned}$$

- **Actual rated power of the turbine rating should be:**

$$\text{Actual turbine rating} = \text{Power rating} / \text{Capacity Factor} = 1.9 / 0.3 = 6.3 \text{ w}$$

The initial model is implemented in MATLAB using simulink/Simscape and the output is measured (volts, amps, power) with similar requirement.

5. SOLAR WIND HYBRID SIMULATION USING MATLAB

Matlab was used to simulate the above set up and the data collected compared with the actual experiment.

Simulink and SimScape were used to model this setup. Components used in the model include:

- Solar Panel containing 10 Solar cells connected in series with short circuit current of 1.29 amps
- open circuit voltage of 2.1 volts (2.1*10 = 21 Volts)
- Diodes, inserted to direct the flow of current in one direction
- Volt meter and amp meter are connected to read the voltage and amperage coming from the Solar panel, and a product of the 2 to measure the power output from the PV and wind mill.

6. MPPT CHARGE CONTROLLER

A Charge controller is used to regulate the charge generated by the wind and solar modules. Charge generated by the renewable energy sources can flow without any regulation causing very high and very low voltage based on the external factors. Excess charge can damage the battery or the load, this charge needs to be regulated, which is done by charge controllers. Maximum Power Point Tracking charge controllers are used to generate most power, by tracking the optimal voltage which can utilize the modules output to its capacity. MPPT controller calculates the optimal voltage required to produce maximum power, and convert the higher voltages to the required optimal value, hence producing the maximum power. For example if the solar panel is rated to produce 20W, but is giving 14 volts and 1.2 amps, resulting in only 16.8 W. When using MPPT, it calculates at what point this voltage can give us the best power and maintains the voltage at that reading using voltage convertors.

The basic experiment did not use MPPT, but in simulation, we calculated the optimal value of resistance for the best power using a step up resistance.

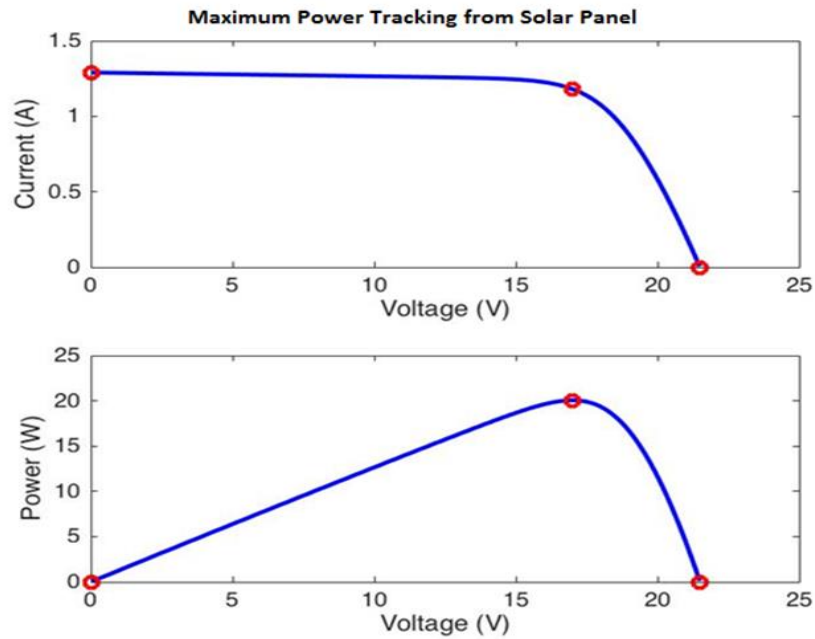

Fig 4. Simulation to find the Maximum Power from Solar Panel

Maximum Power point is achieved at 17 Volts, current 1.29 amps drawing power of 21 Watts from the solar Panel.

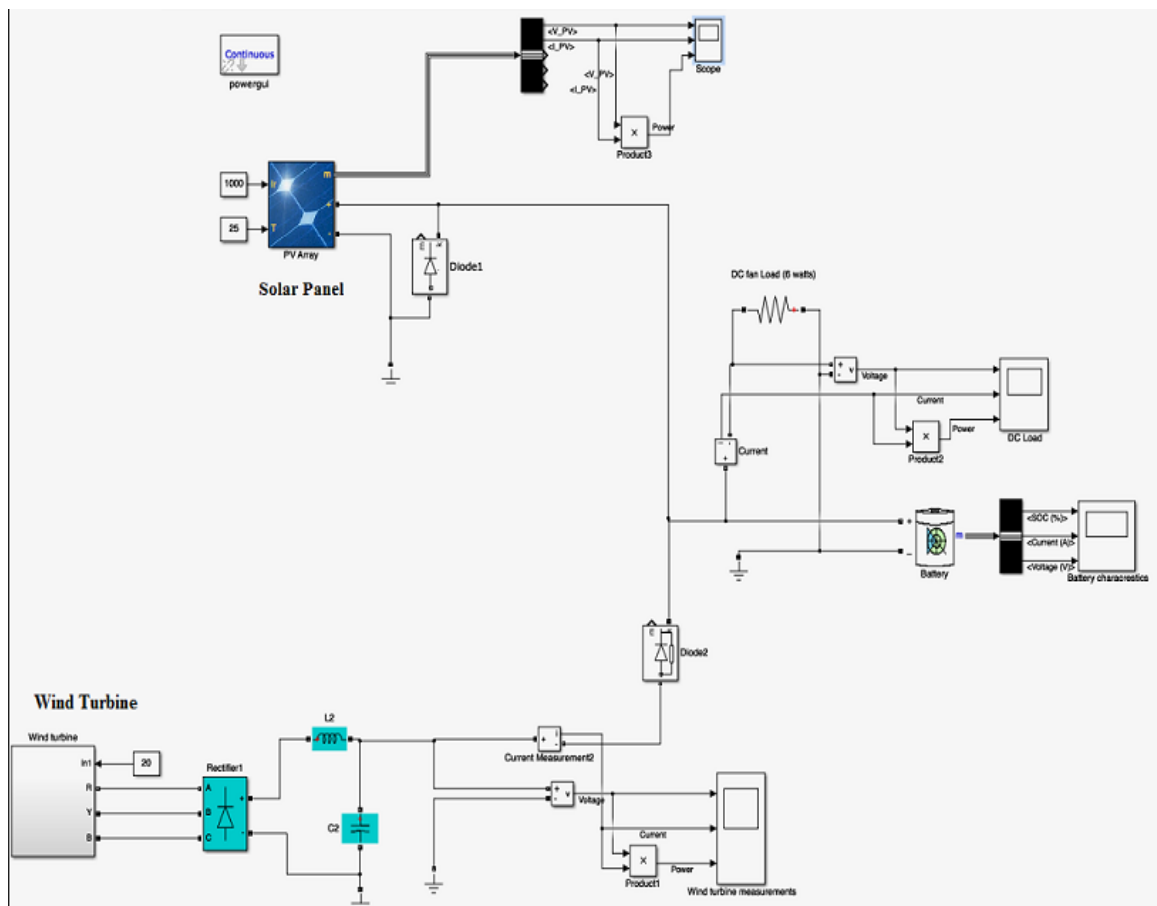

Fig 5. Circuit drawing of the Hybrid system in Simulink

Output captured from Solar Panel: Power output: 18.82 Voltage: 15.18 Volts, current: 1.24amps

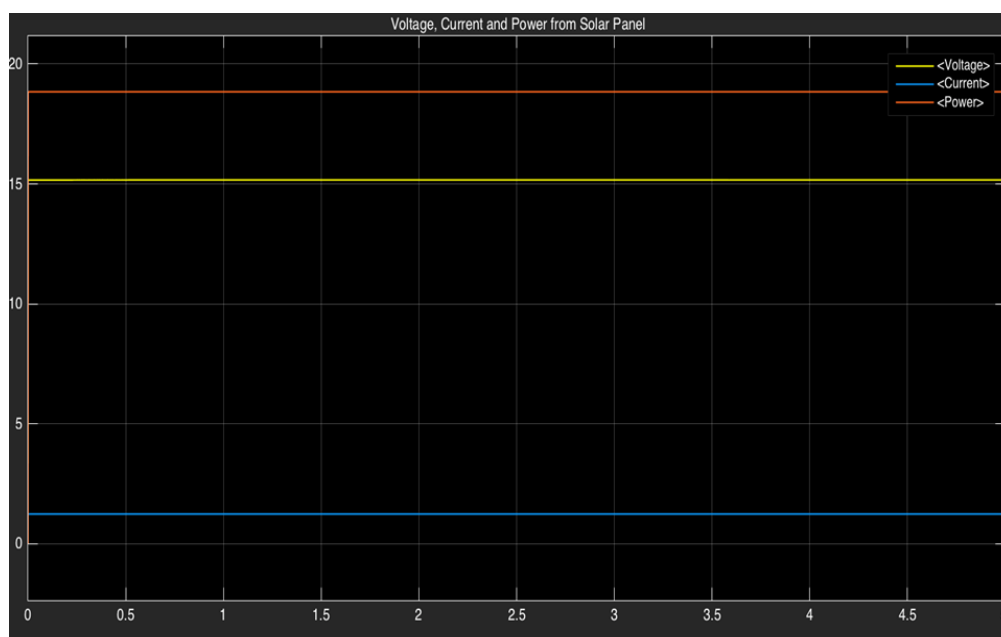

Fig 6. Results from Solar Panel Simulation

Output captured from WindMill (simulation):

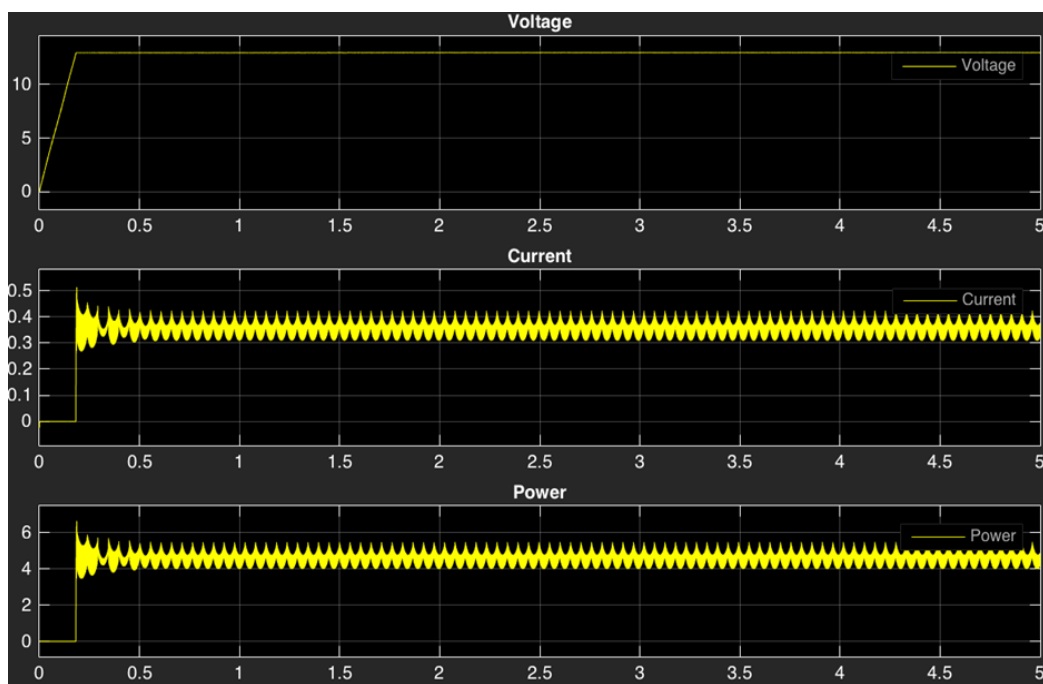

Fig 7. Results from Wind Source Simulation

7. SOLAR WIND EXPERIMENT

Physical experiment was conducted using a Solar panel with following specifications:

- *Maximum Power* – 20 W
- *Voltage at Max Power* – 17V
- *Current at Max Power* – 1.18A
- *Open Circuit Voltage* – 21.5 V

- *Short Circuit Current* – 1.29A
- *Cell Temp* – 25 degrees

Wind Mill is designed with 3 - 16" rotor blades with a rating of 6W, designed to run at 150RPM at speeds greater than 15 KM/hr, to generate 12V. The generator is connected to a rectifier, which converts the AC current to DC, which in turn is fed into the battery.

Solar Panel, wind mill and battery are connected to the hybrid SMT charge controller. Inverter and a DC load was connected to the battery. Couple of 7W CFL bulbs were connected to the inverter and a 12V DC fan was connected to the DC load. Measurements noted from the experiment:

| Source | Voltage | Amps | Power |
|--------|---------|------|-------|
| Solar | 14.27V | 1.21 | 17.2W |
| Wind | 5-10V | >0.1 | >0.5W |



8. CHALLENGES FACED

Wind energy was low and unpredictable in the area where the experiment was conducted. There was high voltage fluctuation due to wind inconsistency, resulting in very low current generation. Wind speeds were intermittent making it difficult for the voltage to reach and maintain at 12V for generating any reasonable charge flow.

9. COMPARISON OF RESULTS

Experimental results were slightly lower than the results from Simulink Simulated model without the MPPT tracking. We will gain more power by using MPPT techniques. Wind power is very insignificant due to low wind speeds at the place where the experiment was conducted. Simulation with the wind and solar gives us better power capacity to charge the battery round the clock.

| Type | Simulation | Experiment |
|-----------------|-------------|------------------|
| Solar - Voltage | 15.18 V | 14.27V |
| Solar - Current | 1.24 amps | 1.21amps |
| Solar - Power | 18.82 watts | 17.2 Watts |
| Wind - Voltage | 13 V | 4 -12 V |
| Wind - Current | 0.35 amps | 0.01 - 0.02 amps |
| Wind - Power | 4.5W | 0.05 - 1 Watts |

10. EXPENSES

Expenses incurred for the small single rural home hybrid system generating 100W+ per day:

| Item | Cost (Rs) |
|-----------------------|--------------|
| Solar Panel | 1000 |
| Charge Controller | 1200 |
| Inverter | 600 |
| Wind Generator | 6000 |
| Battery | 1500 |
| Msc. Equipment | 500 |
| Total Expenses | 10800 |

11. PORTABILITY

The current hybrid set-up was put together with several individual components, and it makes it difficult to move it from one place to another. However in a coastal, rural area, where natural disasters or other causes often necessitate movement of households, portability of energy resources is extremely important. Therefore, another design of the model has been created, which maximises portability:

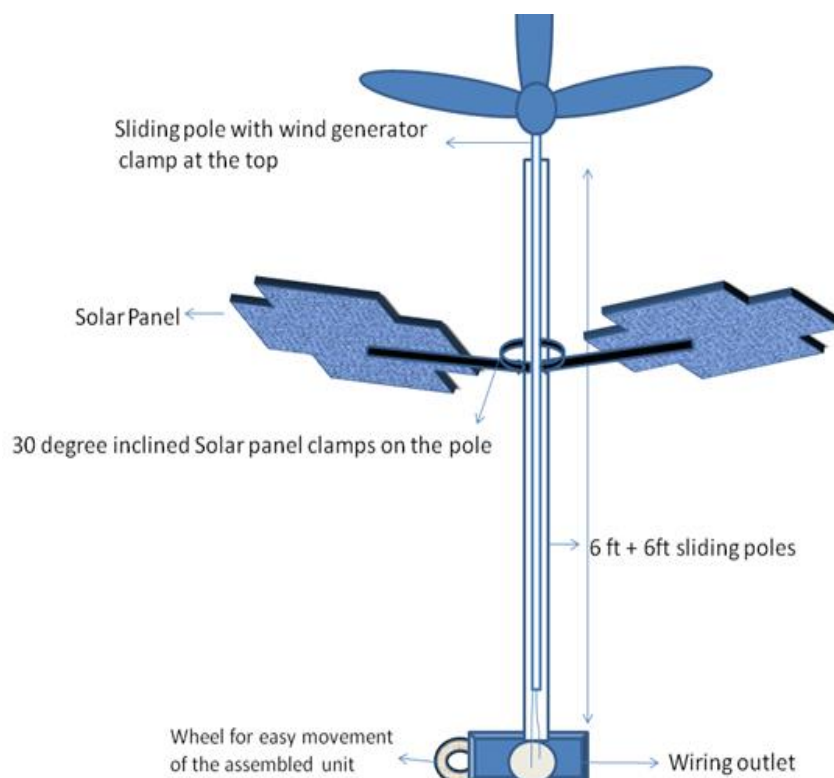

Here, there is a 6ft inner pole within the outer pole to allow adjustability so that the pole and turbines can be made more compact along with giving a height of 12ft for the wind rotors to get more wind at higher elevations. Also two solar panels have been clamped to the outer pole at the 4 ft mark so the unit does not consist of several different parts, which would take up more space and decrease portability. The wiring would be set within the wind pole. The bottom of the wind pole would have the ability to be attached to a set of wheels to make movement of the pole much easier when the set-up has to be shifted.

12. VIABILITY IN SELECTED REGION OF INDIA

Coastal Karnataka region from Ullal to Mangalore to Kundapur stretch along the West Coast of Karnataka have high winds and great sunlight throughout the year and are ideal places to harness both wind and solar power throughout the year:

| Month (2015) | Avg. Wind Speeds Km/hr | Avg. Temp |
|--------------|------------------------|-----------|
| Dec | 17 | 26 |
| Nov | 15 | 27 |
| Oct | 15 | 28 |
| Sep | 20 | 29 |
| Aug | 28 | 31 |
| July | 28 | 31 |
| June | 28 | 32 |
| May | 20 | 32 |
| April | 15 | 32 |
| March | 15 | 29 |
| Feb | 13 | 27 |
| Jan | 15 | 25 |

13. CONCLUSION

Small scale Solar Wind hybrid can be an effective solution for remote off-grid region where there is abundance of sunlight and winds with speeds greater than 15Km/hr. It can be set up as a portable system with just about 10K Rupees per household, increasing it to higher watt output by adding a second solar panel as required. Solar Panel produces consistent energy as long the sun is present during the day time. Solar and wind hybrid can be used to complement each other depending on the external weather conditions. Using MPPT charge controller captures the full capacity of the solar panel gaining 30% more of what a normal charge controller can output.

Bangalore (where the experiment was conducted) is not a good place to consider wind power due to low wind speeds. Wind power is only beneficial in areas where the speeds are higher than 15KM/hr and can sustain over a period of time. Before designing a hybrid system, a thorough study of wind patterns needs to be carried out to assess the feasibility and check if it is useful to have a wind system along with Solar. If there are high winds, it ends up generating a much larger amount of power due to the availability of wind 24 hours, otherwise it is counterproductive to have a hybrid system, considering the Wind generator and the rest of the setup is more expensive compared to Solar panels.

REFERENCES

- [1] <http://www.unep.org/NewsCentre/default.aspx?DocumentID=26856&ArticleID=35621#sthash.LPf9GjIy.OsBsRQG7.dpuf>
- [2] <http://www.ijert.org/view-pdf/12245/hybrid-solar-wind-energy-system-with-mppt-using-cuk-sepic-fused-converter>
- [3] D. S. L. Simonetti, J. Sebasti'an, and J. Uceda, "The Discontinuous Conduction Mode Sepic and ' Cuk Power Factor Preregulators: Analysis and Design" IEEE Trans. On Industrial Electronics, vol. 44,no. 5, 1997
- [4] <http://web.mit.edu/windenergy/windweek/Presentations/Wind%20Energy%20101.pdf>